



Shaft Mounted Geared Motor Series BF

Three phase shaft mounted geared motors for driving machines and equipment of all types.

Standards

- CE-Mark
- INMETRO
- UL
- CCC
- CSA
- Motors according to EN 60034
- ATEX
- EAC
- ISO9001
- ISO14001
- OHSAS18001

Gearbox

- Torque 90 Nm ... 18,500 Nm
- Ratios
 - two-stage: 5.22 - 141.80
 - three-stage: 11.42 - 592.8
- Versatile installation possibilities
- Completely enclosed, sealed against dust and water spray
- Lubrication change first
 - with mineral oil after 15.000 hrs
 - with synthetic oil after 25.000 hrs
- Low noise gearing

Motors

- Power 0.03 kW ... 75 kW
- Mains 110 V ... 690 V, 50/60 Hz
- Enclosure IP 65 (Standard), IP 66 (Optional)
- Connection Standard with CAGE CLAMP®

Options

- Connecting with plug connectors
- With integrated inverter up to 7.5 kW
- IE3 up to 75 kW with ASM
- IE4 up to 11 kW with PMSM

Brakes

- Enclosure IP 65 (Standard)
- Performance and application optimised brake range
- Maintenance friendly design

General

- Corrosion protection CORO1, CORO2, CORO3

Bauer Gear Motor supplies modern drive solutions for all industry sectors in which material must be moved. The customer benefit lies in the robustness and durability of our products. The simple and cost effective installation, the minor service necessity and the high efficiency reduce the costs throughout the whole life of the drive. The Bauer-Service is at your disposal world-wide.

Bauer geared motors make drive solutions possible in the power range 0.03 to 75 kW.

Proximity to the customer, both geographically and psychologically, is an important pre-condition for good cooperation. Our highly qualified advisors, technicians and fitters are working for you round the world. They speak your language – even in the transmitted sense.



- CAGE CLAMP® connection technology as standard.
- Optional with conventional terminal board

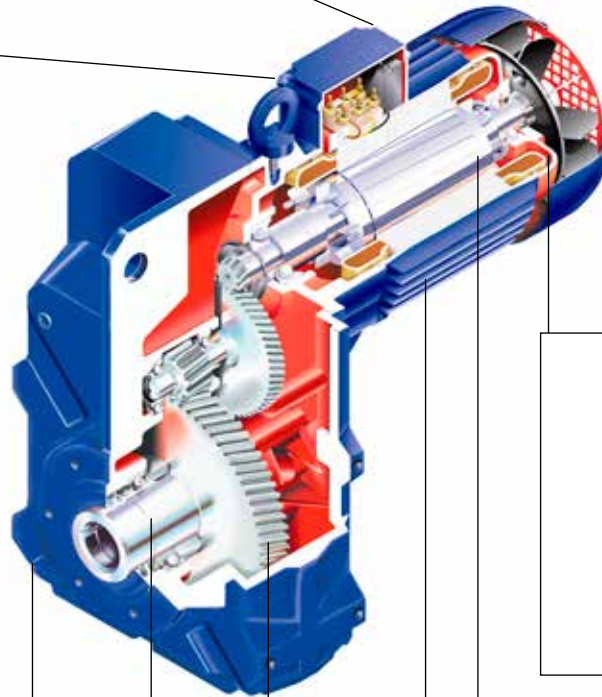

- The stator winding is manufactured from high quality enamelled copper wire with state-of-the-art three layer insulation in the groove and winding head.
- The stator winding is impregnated with a damp-proof and drip-free resin.
- The electrical design of the motor is adapted to the gearbox.

- State-of-the-art gearbox housing designed for operation under harsh conditions.
- Compact closed housing is ideal for preventing lubricant loss and dirt build-up.
- High tensile cast housing.
- Vibration-free housing, noise absorbent and resistant against chemical effects.
- The housing is machined in a single clamping process

- Aluminium die cast cage rotor ensures a high reliability at high starting torques and low starting currents.
- Pull-up torques are mostly avoided

- Series BF as standard in 2-stage design, as from BF80 3-stage.
- Attachment by means of hollow shaft, solid shaft, torque arm, flange or foot.
- Higher ratios available through attachment of a purpose built pre-stage or pre-connected gearbox.
- Reduced axial space requirement using hollow shaft design with torque arm. Coupling no longer necessary.
- No expensive leveling as foundation and foot plate or flange not required.

- Stator housings with jacket and cooling fins are manufactured in one casting and ensure efficient heat dissipation.
- Motor housings, bearing covers and terminal boxes made of corrosion resistant aluminium die casting.
- Stator housings also available in cast iron.
- Spacious terminal box also completely sealed against dust and water spray.
- A large measure on safety through sturdy cable lugs on the winding ends.
- Handy terminals allow easy connection.

- Gear wheels made of high tensile and case hardened steel.
- Highly wear resistant through flank hardness of 60-62 HRC.
- Impervious to shock.
- Tooth flanks shaved, hobbed or ground.
- Strong, non-flexible pinion shafts and bearings guarantee an exact tooth meshing.

Bauer assumes no liability or responsibility for misprints and errors in catalogues, brochures and other printed documentation. Bauer reserves the right to make changes to products without prior notice, including to products that have already been ordered, unless contractual technical specifications are affected by such changes. All trademarks in these publications are the sole and exclusive property of the relevant companies. Bauer and the Bauer logo are trademarks of Bauer Gear Motor GmbH. All rights reserved. Images: Fotolia, Altra und Bauer Archive

